

MINI SPIRALLING TOOL INSTRUCTIONS

OVERVIEW

MAIN SHAFT
 INDEXING TOOL
 BRASS THUMBSCREW BEARING
 17 TOOTH SPIRALLING WHEEL
 27 TOOTH SPIRALLING WHEEL
 ALLEN KEY

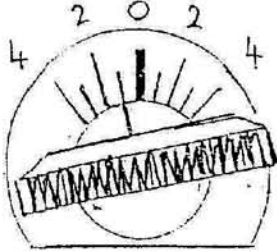

TOOL SET UP.

Using the small grub screws on the side of the Indexer, you can lock the shaft to the desired pitch of the Spiral you want to cut.

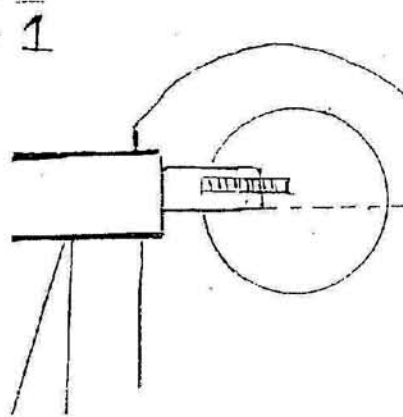

1. LATHE SET UP

Set the lather speed to approximately 500rpm. Set the tool rest so the bottom of the main shaft is on the centre line.

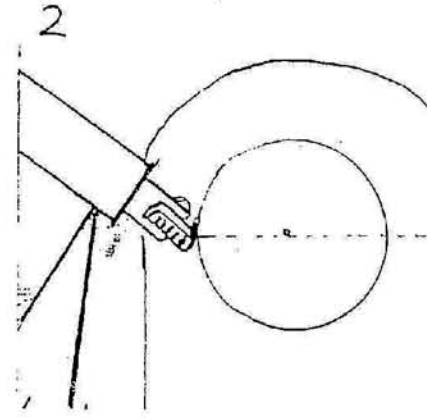

2. Gently place the cutter against the wood, then raise the handle as the cutter spins, cutting on the centre line of your turning.

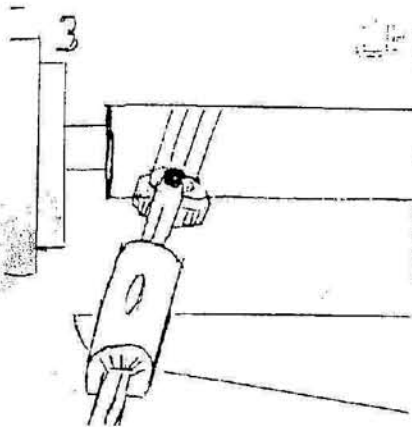

3. Stop the lathe and check you have a clean cut.

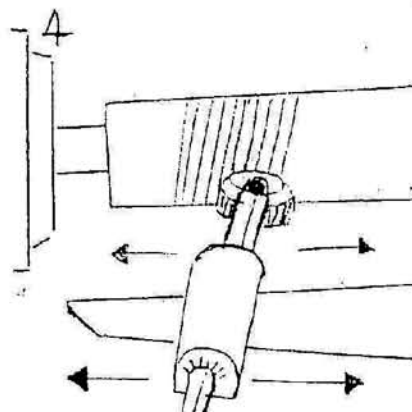

4. Turn the lathe back on and with the tool flat, gently present the cutter back on to the wood and again gently raise the handle to allow the cutting wheel to follow the grooves you made in step 2. Then move the tool along the wood to the length of the Spiral required, cutting deeper on each pass. Repeat this until the required depth of your Spiral has been cut.

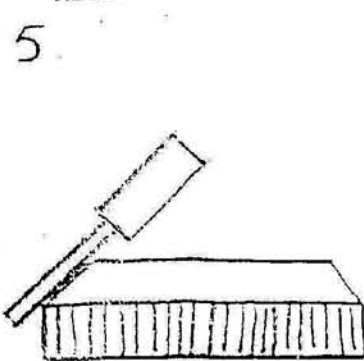

5. SHARPENING

To sharpen the Spiralling wheels, use a Diamond File or a stone on the Bevelled Face.

NOTE. FOR THE BEST RESULTS IT IS RECOMMENDED TO USE A CLOSE GRAIN WOOD.